

- 1 MATES WITH AMP CONNECTOR PART NO. 480706.
- △2 FLAME RETARDANT CLASSIFICATION OF MATERIAL IS 94V-2.
- 3 PARTS MUST COMPLY WITH AMP SOLDERABILITY SPEC 109-11-3.
- △4 CONTACT IS STAMPED FROM PRE-PLATED STOCK WHICH IS PLATED OVERALL WITH 0.00127 [.000050] NICKEL, THEN STRIPED WITH 0.00076 [.000030] GOLD IN CONTACT AREA INDICATED AND TIN-LEAD ON SOLDER TAIL END.
- △5 CONTACT IS PLATED OVERALL WITH 0.00127 [.000050] NICKEL, THEN 0.00076 [.000030] GOLD OVER CONTACT LENGTH INDICATED AND MATTE TIN ON SOLDER TAIL END.
- △6 SUPERSEDED BY 350990-5

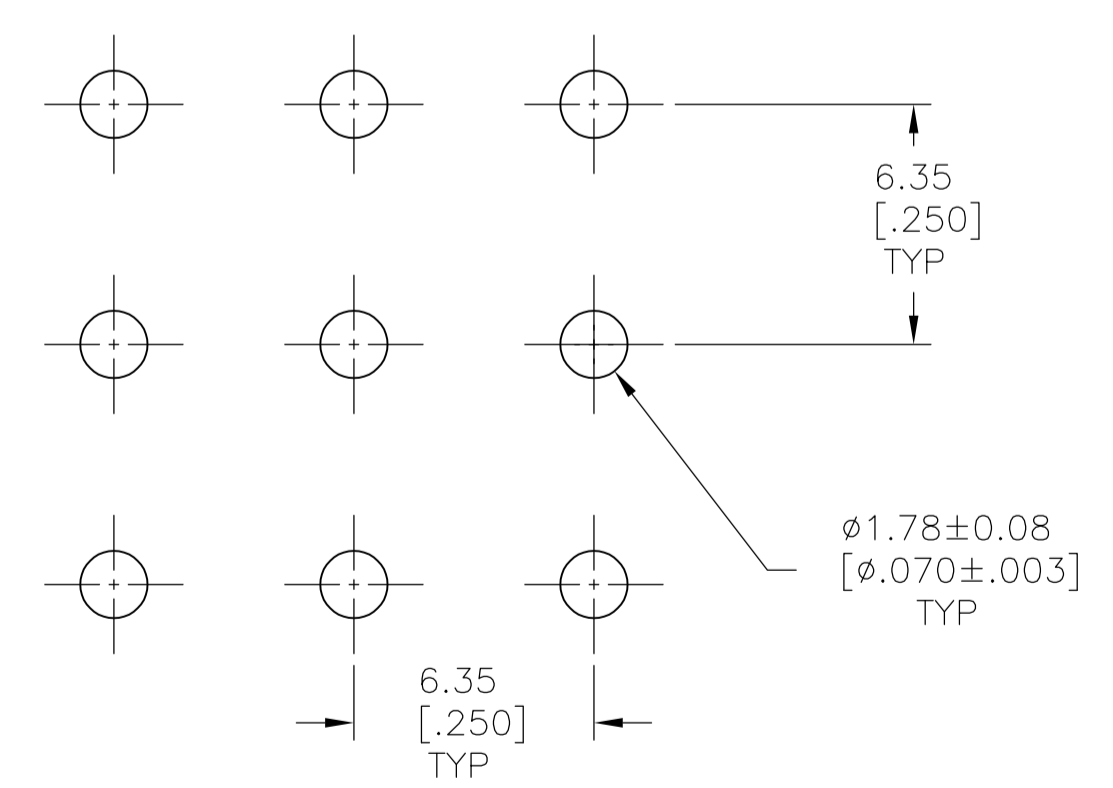

RECOMMENDED LAYOUT FOR 3.18 [.125] THICK PC BOARD

PH BRZ GOLD △5	NYLON, NATURAL △2	350990-5
PH BRZ TIN	NYLON, NATURAL △2	350990-4
△6 PH BRZ GOLD △4	NYLON, NATURAL △2	350990-3
CONTACT	HOUSING	PART NO

THIS DRAWING IS A CONTROLLED DOCUMENT.		DIN K. WHITAKER 11OCT2005	TE Connectivity
DIMENSIONS: mm [INCHES]		CHK S. RIDGILL 11OCT2005	
TOLERANCES UNLESS OTHERWISE SPECIFIED:		APVD S. RIDGILL 11OCT2005	NAME SOCKET HEADER ASSEMBLY 9 CIRCUIT, LONG TAIL, UNIVERSAL MATE-N-LOK (TM)
0 PLC ±	1 PLC ±	APPLICATION SPEC	SIZE A1
2 PLC ±	3 PLC ± 0.13 [.005]	WEIGHT	SCALE 5:1
4 PLC ±	ANGLES ±	CUSTOMER DRAWING	SHEET 1 OF 1
MATERIAL SEE TABLE	FINISH SEE TABLE	REV G2	REV G2