

THIS DRAWING IS UNPUBLISHED. RELEASED FOR PUBLICATION .19  
 © COPYRIGHT 19 BY AMP INCORPORATED. ALL INTERNATIONAL RIGHTS RESERVED.

LOC	DIST	P	F	REVISIONS			
ZONE	LTR	DESCRIPTION	DATE	APPD			
G	14			J	EC 0720-0279-93	6-21-93	BB

**AMP**  
WIRE RANGE  
  
2 AWG  
STRANDED

**METRIC**  
DIMENSIONS LISTED IN mm [ INCHES ]

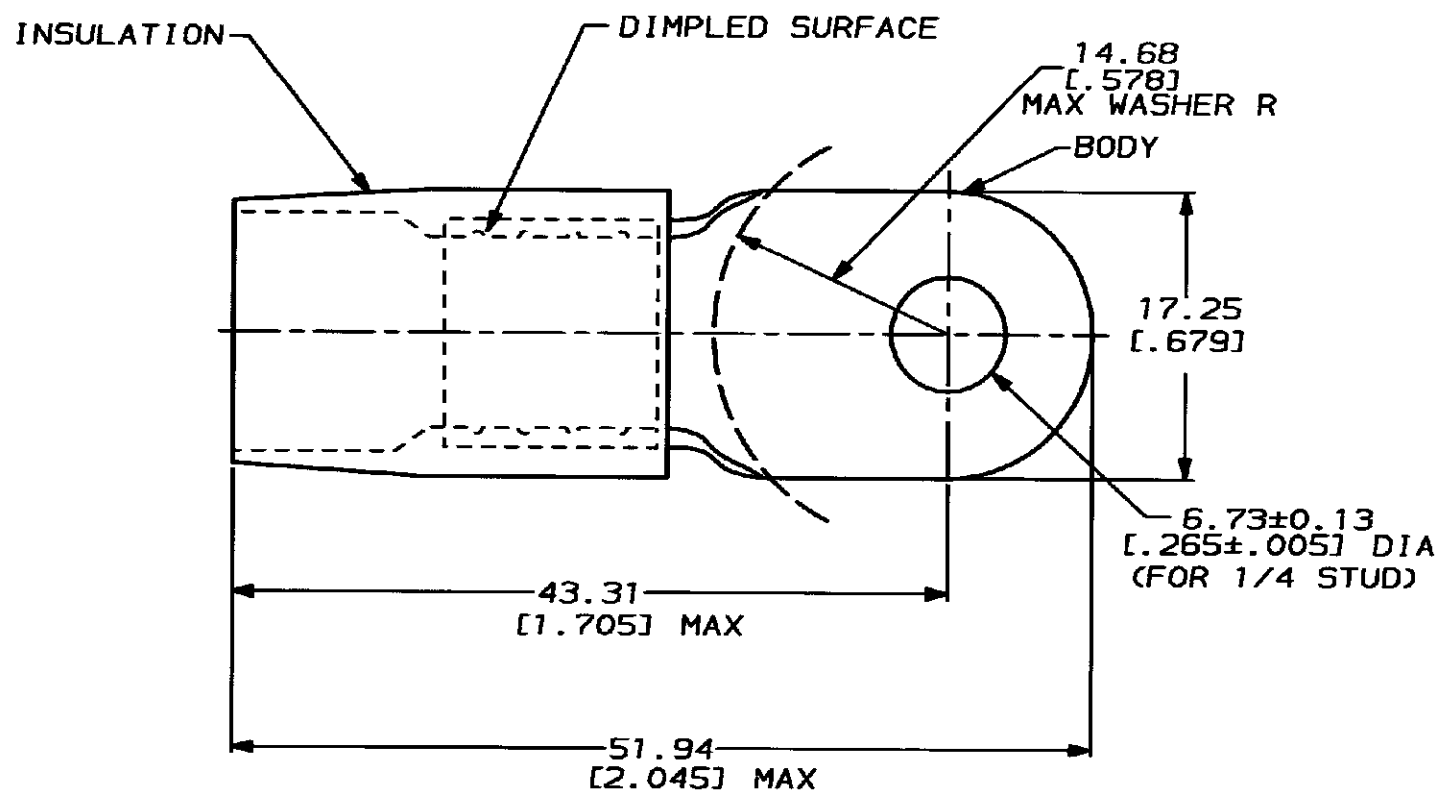

1. TONGUE MATERIAL THK 1.45±0.08 [0.057±0.003]  
FOR 11.89 [0.468] MAX WIRE INS DIA

<b>AMP INCORPORATED CUSTOMER SERVICE SYSTEMS</b>		MAX RECOMMENDED OPERATING TEMPERATURE: 105°C	MS25036-126 CLASS 2	MILITARY P/N AND CLASS	QTY	LOOSE PC	324053	
FOR ADDITIONAL PRODUCT INFORMATION OR COPIES OF DRAWINGS AND TECHNICAL DOCUMENTS	PRODUCT INFORMATION CENTER 1-800-522-6752	VOLTAGE RATING: -	DO NOT SCALE PRINT. UNLESS SPECIFIED	DR 6-21-93 S.S. GOULDEN	AMP Incorporated Harrisburg, PA 17105-3608	PART NO		
FOR APPLICATION TOOLING INFORMATION	TOOLING ASSISTANCE CENTER 1-800-722-1111	CIRCULAR MIL AREA: 26.7-42.4mm² [52,600-83,700] STRANDED	TOLERANCES ON: 2 PLC DEC ± 0.20(0.008) 3 PLC DEC ± - ANGLES ± -	CHK 6-21-93 R. HERSEY	NAME	TERMINAL, RING TONGUE, TERMINYL WIRE SIZE: 2 AWG		
FOR ORDER ENTRY	1-800-526-5142	THIS DRAWING IS A CONTROLLED DOCUMENT FOR AMP INCORPORATED. IT IS SUBJECT TO CHANGE AND THE CONTROLLING ENGINEERING ORGANIZATION SHOULD BE CONTACTED FOR THE LATEST REVISION.	MATERIAL COPPER PER ASTM B-152 NYLON (MIL-M-20693) TYPE 1 COLOR: RED	APPD 6-21-93 B. BARE	PRODUCT SPEC	SIZE	CAGE CODE	DRAWING NO
AMP 1470-15 REV 3-92 21 JUN 1993 08:53:13 AMPT1122 <U128A>DEPT1132>AMPT1122>U.CUSTOMINYL			FINISH TIN PLATE PER MIL-T-10727	APPD 6-21-93 H. ELLIS	APPLICATION SPEC	B	00779	C-324053
				WEIGHT -		SCALE	NTS	SHEET 1 OF 1

CUSTOMER DRAWING