

THIS DRAWING IS UNPUBLISHED. RELEASED FOR PUBLICATION
 (C) COPYRIGHT 19 BY AMP INCORPORATED. ALL RIGHTS RESERVED.

LOC		DIST		REVISIONS			
P	LTR	DESCRIPTION		DATE	DWN	APVD	
		D		REVISED PER 063A-0208-02	17MAY02	MF	KR

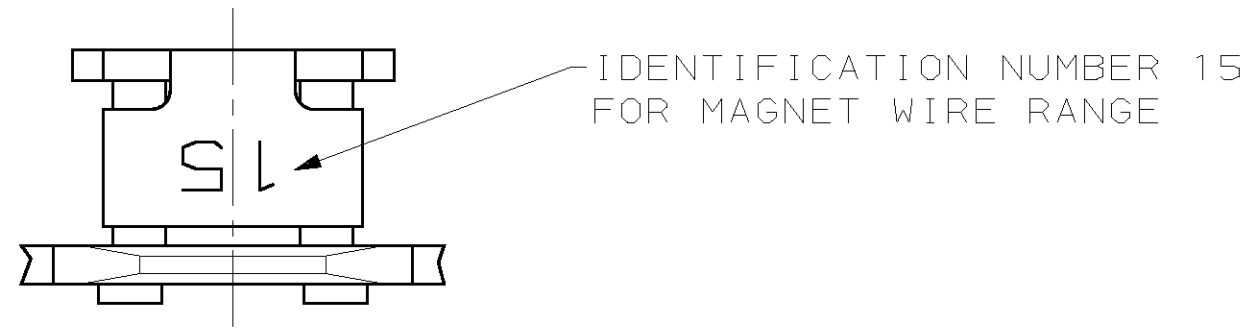

- 1 CONTINUOUS STRIP ON REELS WITH TERMINALS LOCATED ON 5.59±0.08 [.220±.003] CENTERS. SLOT TERMINATES A SINGLE MAGNET WIRE ONLY. COPPER RANGE: 0.57-0.81mm [#23-#20] AWG.
- 2 CONTACT LUBE OVER 0.00127 [.000050] MIN NICKEL PLATE.

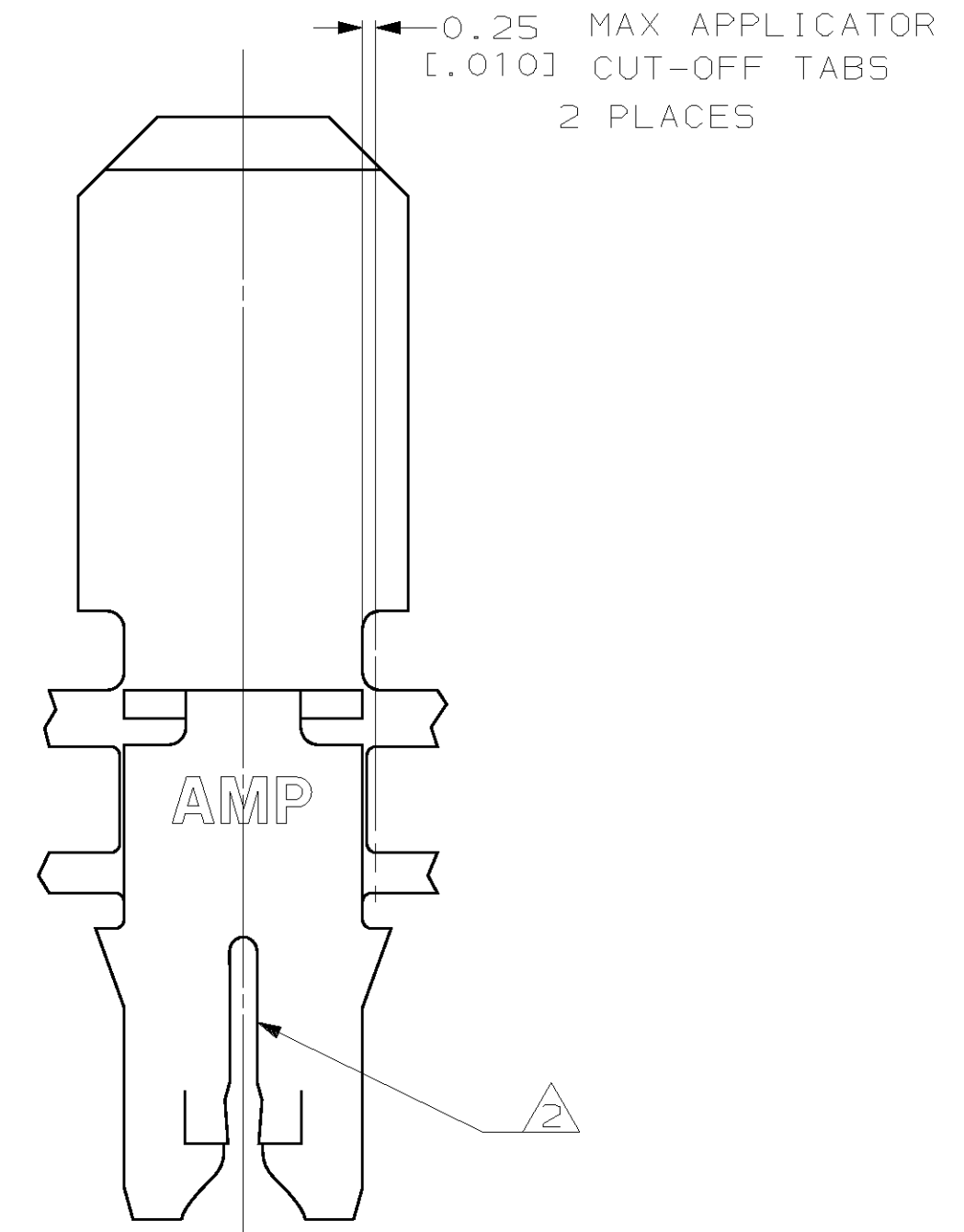
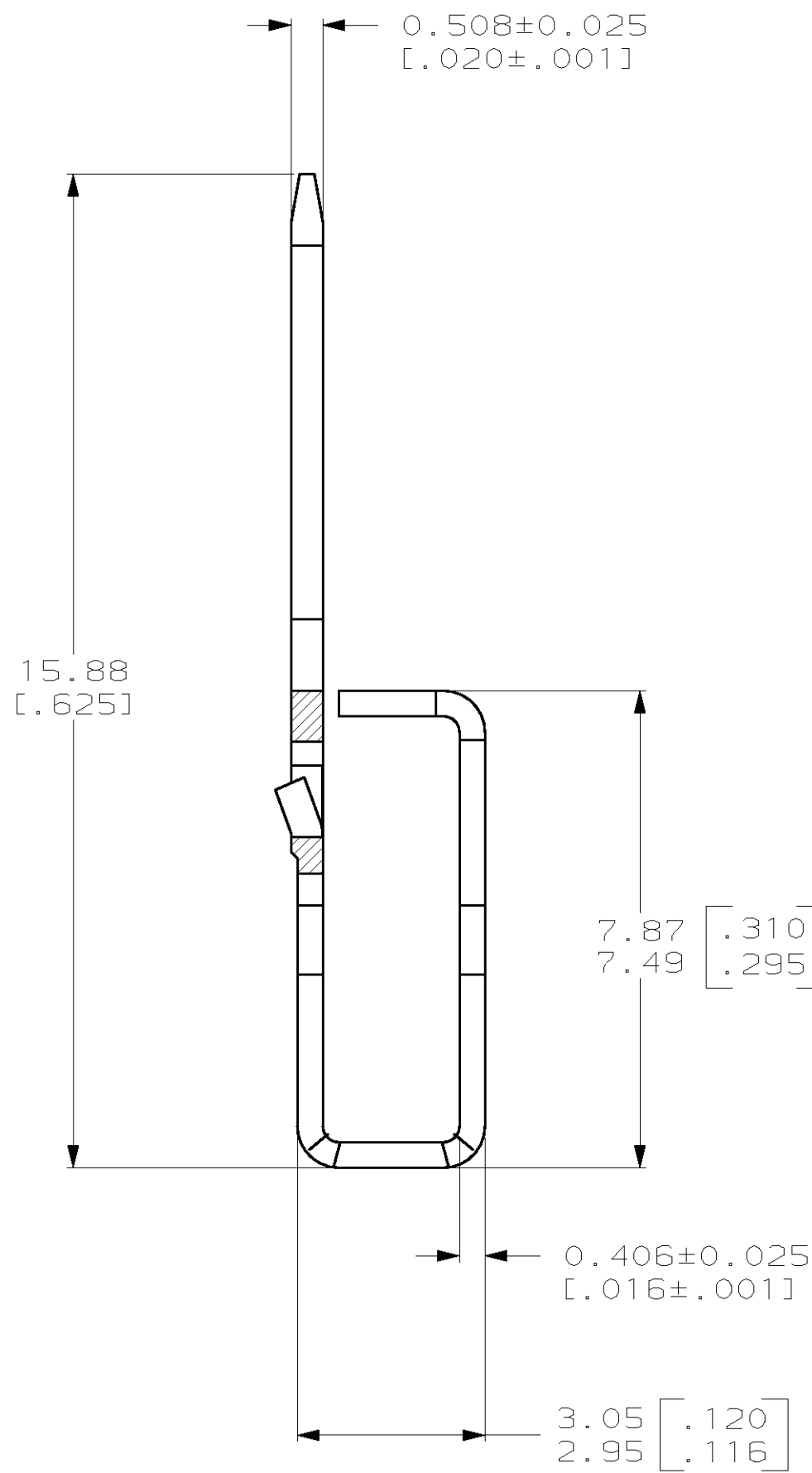
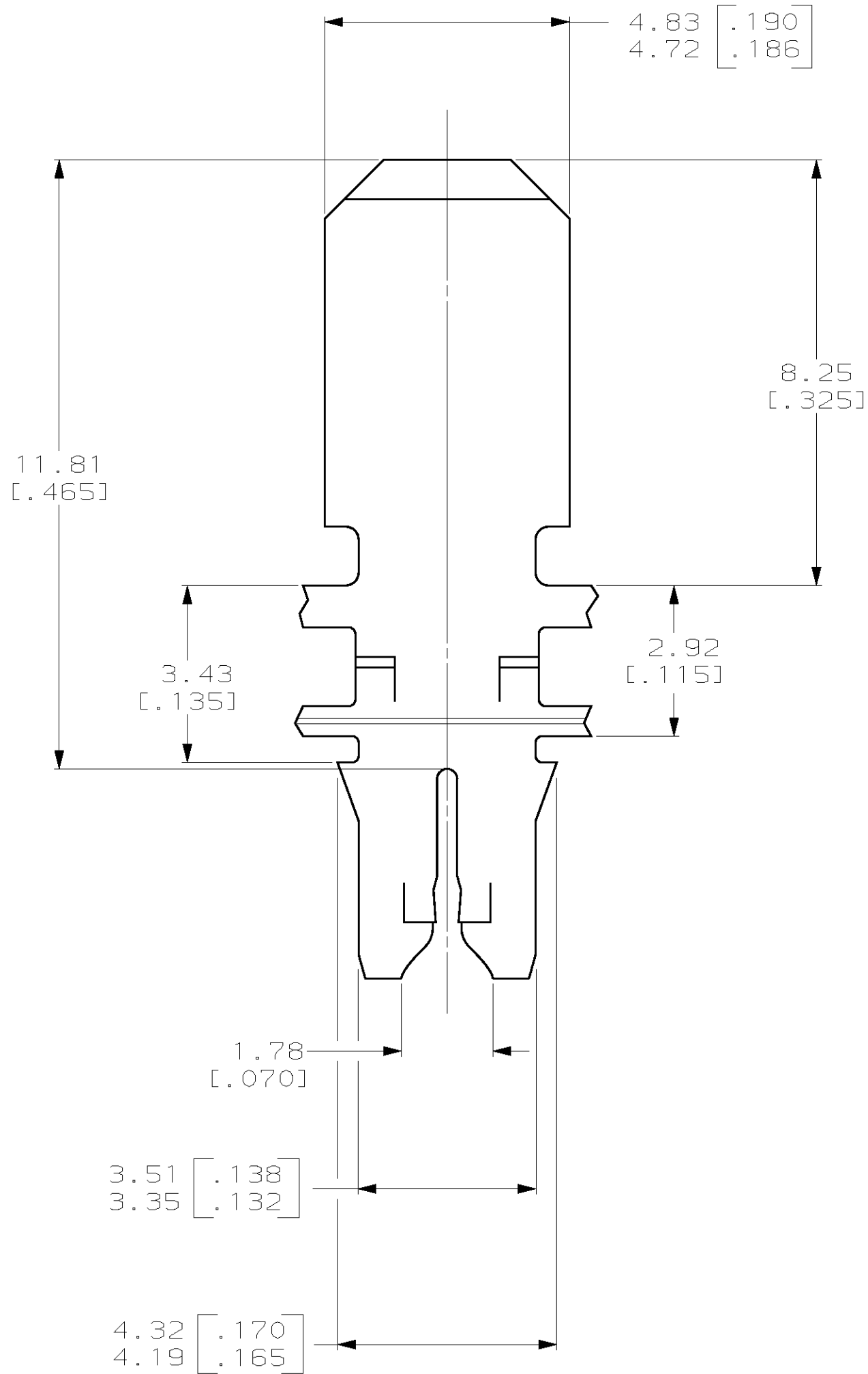

1217493-1
PART NUMBER

THIS DRAWING IS A CONTROLLED DOCUMENT.		DWN	20SEP2000	AMP Incorporated Harrisburg, PA 17105-3608
DIMENSIONS: mm [INCHES]		CHK	21SEP2000	
TOLERANCES UNLESS OTHERWISE SPECIFIED: 0 PLC ±- 1 PLC ±- 2 PLC ±0.25 [.010] 3 PLC ±- 4 PLC ±- ANGLES ±-		APVD	21SEP2000	
MATERIAL: 4M PRE-MILLED BRASS		NAME: KURT A. RANDOLPH PRODUCT SPEC: 108-2012 APPLICATION SPEC: 114-2046 FINISH: 4		
SCALE: 10:1		SIZE	A2	RESTRICTED TO
SHEET 1 OF 1		CAGE CODE	00779	
REV D		DRAWING NO	1217493	
CUSTOMER DRAWING		WEIGHT	-	